

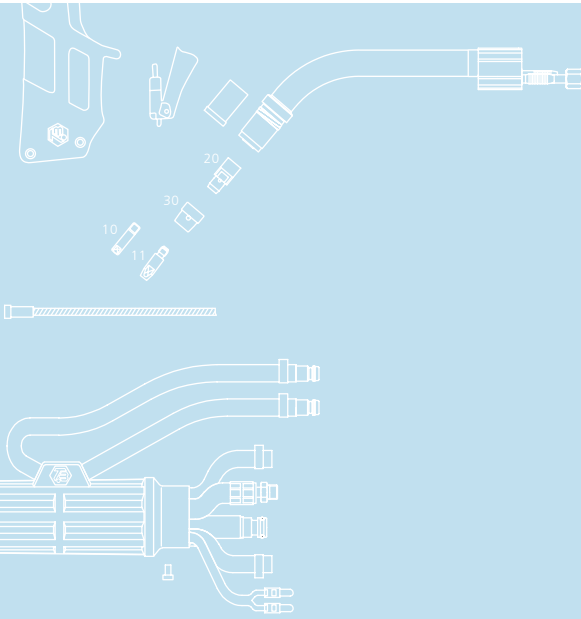

Top 2000 TBI 5W



Water cooling

Compact and lightweight

Screw-on gas nozzles

Technical data

MIG / MAG (GMAW) Semi-automatic welding torch TBI 5W

Rating at 100% duty cycle
(10 min. cycle)

- Mixed gas: 290 A
- CO₂: 320 A

Cooling method: Water cooling

Wire diameter: 0.8 - 1.2 mm

Gas flow: 12 l/min

Technical specification: according to IEC 60974-7

Weight with 1.5m cable: 1.50 kg

Connection: Euro-Central connector
other connectors are available upon request.

Torch rating will be reduced when using pulsed-arc power sources. Special torch necks and custom lengths of the cable assembly are available upon request.

Ordering Information

TBi 5W ESW, 50° bent 176P4425_0*

* At the blank, please insert 3, 4 or 5 for a torch length of 3, 4 or 5m.

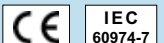

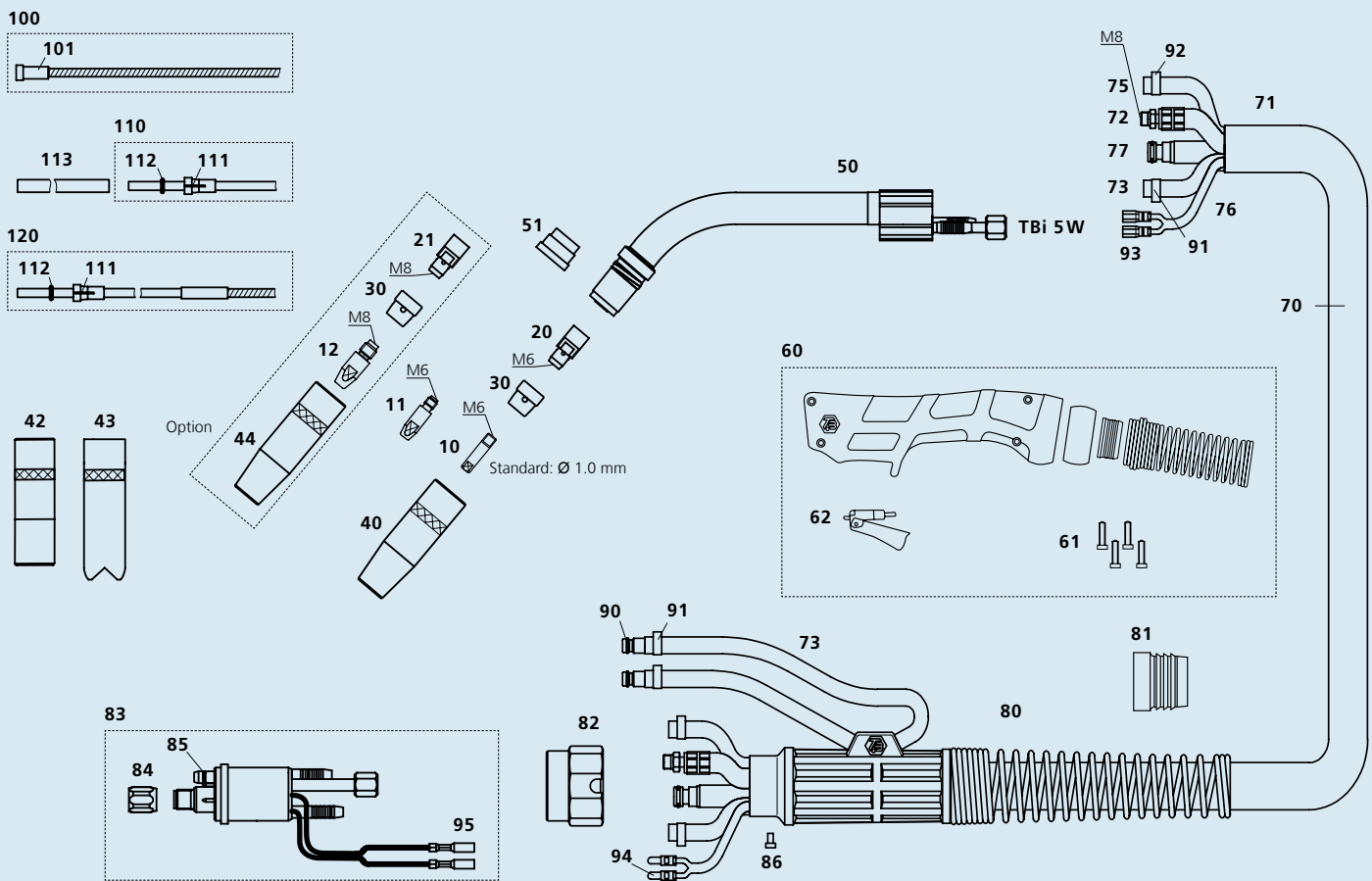

Pos. Description

Part. No.

Pos. Description

Part. No.

Contact tips

▶ 10	Contact tip M6x25, Ecu	340P_1073*
10	Contact tip M6x25, CuCrZr	340P_3073*
10	Contact tip M6x25 Alu, Ecu	341P_1073*
11	Contact tip M6x28, Ecu	340P_1069*
11	Contact tip M6x28, CuCrZr	340P_3069*
11	Contact tip M6x28 Alu, Ecu	341P_1069*
12	Contact tip M8x30, Ecu	340P_1262*
12	Contact tip M8x30, CuCrZr	340P_3262*
12	Contact tip M8x30 Alu, Ecu	341P_1262*

Tip holders

▶ 20	Tip holder M6, CuCrZr	342P006176
21	Tip holder M8, CuCrZr	342P008176

Gas diffusers

▶ 30	Gas diffuser	174P102090
30	Gas diffuser, heavy duty	174P102091

Gas nozzles

▶ 40	Nozzle conical diam. 12.5 mm	345P012176
40	Nozzle conical diam. 12.5 mm HD	345P012276
42	Nozzle cylindrical diam. 17 mm	345P011176
43	Spot weld nozzle diam. 17 mm	345P125176
44	Nozzle conical diam. 12.5 mm for M8 contact tip	345PA12176

Spare parts

50	Torch neck TBi 5W, 50°	176P101006
51	Insulating bushing	176P102018
60	Handle blue, watercooled, cpl. kit	380P220401
61	Cross recessed screw M3.5x14	100P008413
62	Trigger, red, 2 poles	385P021016

70	Cable assembly TBi Top 2000, 2-C	171P4B45_0*
71	Fabric outer cover 25x1.5 mm, cpl.	307P2528_A*
72	Water-power cable Top 2000, blue, 2-C	316P1622_0*
73	Water hose 2-C, black, 5x1.5 mm	303P070000
75	PVC-Gas hose, black 4.5x1.5 mm	302P010000
76	Control cable x.30 m cpl.	301P2304_0*
77	Wire conduit yellow (Top 2000)	356P0C0C_0*
80	Cable support 3 parts cpl. with spring	701P101071
81	Clamping ring for outer cover	600P102201
82	Adaptor nut	701P001013
83	Central adaptor ESW cpl., moveable pins (Top 2000)	701P101006
84	Sleeve nut M10x1	701P002005
85	O-ring 4.0x1.0 mm (gas nipple)	365P100040
86	Slotted screw M4x6	100P008401
90	Quick connector	701P002064
91	Hose clamp Ø 9.5 with ring	373P100095
92	Hose clamp Ø 8.7	371P000087
93	Cable lug, flat	375P000023
94	Insulated connector, male, round	375P000004
95	Insulated connector, female, round	375P000003

Wire guides

100	Liner w/ insulation blue (x.40 m) for wire 0.8-1.0	324P1545_4*
▶ 100	Liner w/o insulation (x.40 m) for wire 1.0-1.2	322P2045_4*
101	Collet for liners diam. 4.5 mm	330P025045
110	PTFE-liner blue (x.50 m) for wire 0.8-1.0	326P1540_5*
110	PTFE-liner red (x.50 m) for wire 1.0-1.2	326P2040_5*
111	Collet for liners 2.0x4.0 mm	331P020040
112	O-ring 3.50x1.50 mm (for liner)	365P150035
113	Support tube 5x4.4 mm, L=150 mm	329P544150
120	PA-Alu wire guide (x.50 m) for wire 1.0-1.2	328P2040_A*

▶ = Standard equipment

* At the blank, please insert suitable information for torch length or wire diameter, e.g. 08 for 0.8 mm or 3 for 3 mm.

© 2012 TBI Industries GmbH. All rights reserved. Subject to change without notice. Warranty only when using original TBI consumables and spare parts. Excerpts and reprints not permitted. Nr. DOKP112152, 07/2012.

TBI Industries GmbH
Ruhberg 14
D-35463 Fernwald-Steinbach
P.O. Box 67
D-35461 Fernwald-Steinbach

Tel. + 49 6404 9171-0
Fax. + 49 6404 9171-40
Internet: www.tbi-industries.com
E-mail: info@tbi-industries.com