

TBi AT 420 / 420S TIG Machine torch

High performance – Easy handling

- Reliable cooling of the tungsten electrodes and high performance current transfer over the newly developed electrode clamp
- Optimized gas protection
- Jumbo gas nozzles are compatible
- The electrode can be precisely positioned by means of the optional setup tool.
- S-version: The electrode can be lowered even during operation of the torch by turning the upper knob.

Technical Data

TBi AT 420 / 420S TIG Machine torch

Rating at 100% duty cycle
(10 min. cycle)

	AT 420	AT 420S
- AC	400 A	280 A
- DC	500 A	400 A
Elektrode diameter	1.6 - 6.4 mm	1.6 - 4.8 mm
Cooling method	water cooled	
Technical specification	according to IEC 60974-7	

Ordering information

Machine connection	Length	AT 420	AT 420S	AT 420 - with cold wire guide -	AT 420S
M12x1 (Standard)	4.0 m	491P437004	491P427004	495P437004	*
	8.0 m	491P437008	491P427008	495P437008	*
TSB 3550	4.0 m	491P437074	491P427074	495P437074	*
	8.0 m	491P437078	491P427078	495P437078	*
Euro WZ-0 (suitable for TBI PF 16)	4.0 m	491P437054	491P427054	495P437054	495P427054
	8.0 m	491P437058	491P427058	495P437058	495P427058

* on request

The torch is supplied without consumables and setup tool, please order separately as needed. For other lengths and connections, please contact our sales team.

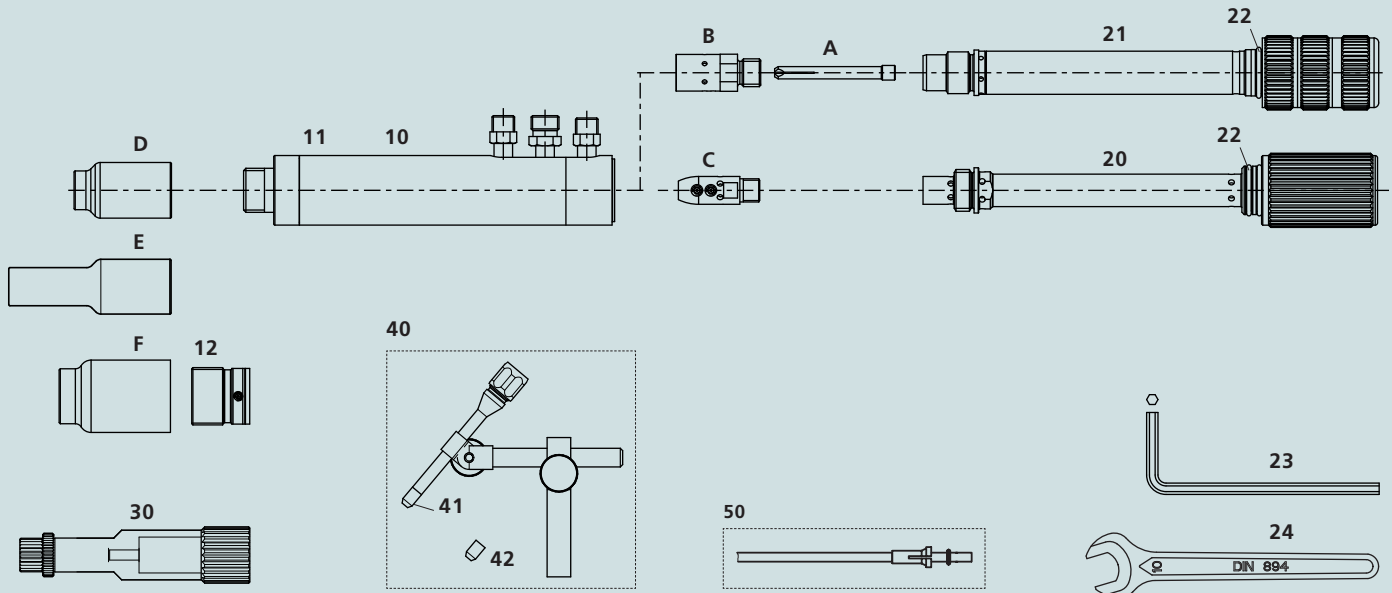

Pos. Description

Spare parts

Pos.	Description	Part no.
10	Torch body AT 420 (S) / AT 410 (S)	491P400005
11	Insulator, ceramic	491P102116
12	Adaptor for Jumbo gas nozzle	491P102115
20	Electrode holder cpl. AT 420	491P400009
21	Electrode holder cpl. AT 420S / AT 410S	491P400007
22	O-ring	365P200180
23	Hex wrench size 2.5	391P000036
24	Open-end wrench size 11	391P102027

Pos. Description

Accessories

Pos.	Description	Part no.
30	Setup tool for electrode	491P101020
40	Cold wire guide cpl.	481P101025
41	Guide nozzle, 0.8-1.0 mm	481P102018
42	Guide nozzle, 1.2-1.6 mm	481P102019
50	PA-liner cpl. (4.50 m) for wire 0.8-1.2 mm	328P204045
50	PA-liner cpl. (8.50 m) for wire 0.8-1.2 mm	328P204085
50	PA-liner cpl. (4.50 m) for wire 1.2-1.6 mm	328P234745
50	PA-liner cpl. (8.50 m) for wire 1.2-1.6 mm	328P234785

Consumables

		Ø 1.6 mm Ø 1/16"	Ø 2.4 mm Ø 3/32"	Ø 3.2 mm Ø 1/8"	Ø 4.0 mm Ø 5/32"	Ø 4.8 mm Ø 3/16"	Ø 6.4 mm Ø 1/4"
A	Collet L=52 mm	10N23 D	10N24 D	10N25 D	54N20 D	54N20 D	-
		401P180501	401P180502	401P180503	401P180504	401P180506	-
B	Gas lens	491P391301	491P391302	491P391303	491P391304	491P391305	-
C	Electrode clamp	491P102120	491P102121	491P102122	491P102123	491P102124	491P102125

		No. 4 Ø 6.5 mm Ø 1/4"	No. 5 Ø 8.0 mm Ø 5/16"	No. 6 Ø 9.5 mm Ø 3/8"	No. 7 Ø 11 mm Ø 7/16"	No. 8 Ø 12.5 mm Ø 1/2"	No. 11 Ø 17.5 mm Ø 11/16"	No. 12 Ø 19 mm Ø 3/4"	Ø 24.0 mm
D	Ceramic gas nozzle Standard, L=42 mm	54N18	54N17	54N16	54N15	54N14	54N19	-	-
		401P222200	401P222201	401P222202	401P222203	401P222204	401P222206	-	-
E	Ceramic gas nozzle Long L=76 mm	54N18 L	54N17 L	54N16 L	54N15 L	54N14 L	-	-	-
		401P222211	401P222207	401P222208	401P222209	401P222210	-	-	-
F	Ceramic gas nozzle Jumbo L=48 mm	-	-	57N75 401P201451	-	57N74 401P201452	-	53N87 401P222251	53N89-L 401P222253

© 2012 Tbi Industries GmbH. All rights reserved. Subject to change without notice. Warranty only when using original Tbi consumables and spare parts. Excerpts and reprints not permitted.
Nr. DOKP122211, 10/2012.