

Aufbau der WIG-Kaltdrahtzuführung am Brenner SR 9/SR 20  
 Details of TIG-Cold-Wire-Feeding for Torch SR 9/SR 20  
 Installation du TIG-fil froid sur la torche SR 9/SR 20  
 Detalles del TIG alimentación de hilo frío en la antorcha SR 9/SR 20

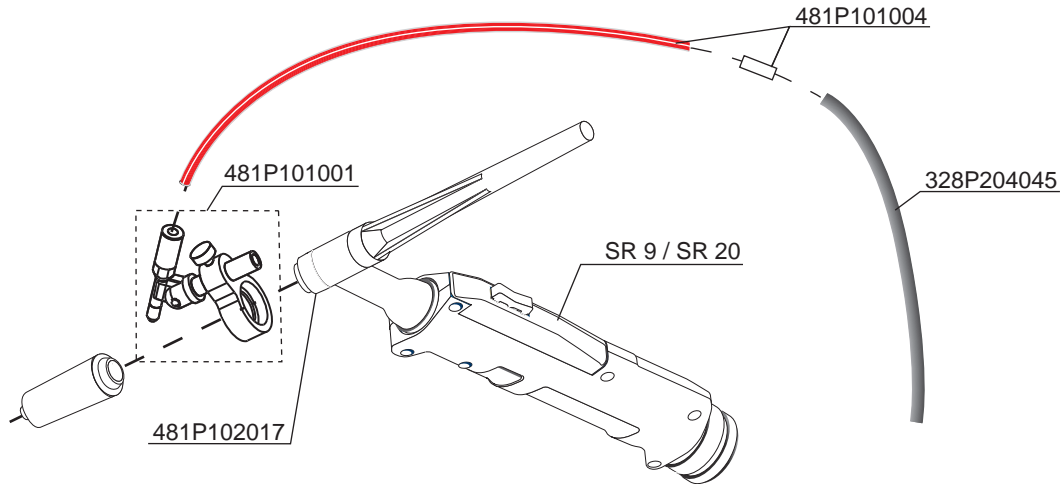

328P204045	PA-Drahtführung (4.50m) für Draht 1.0-1.2	PA-liner (4.50m) for wire 1.0-1.2	Gaine-PA (4.50m) fil 1.0-1.2	PA-Guia (4.50m) para hilo 1.0-1.2
481P101004	PTFE-Seele kpl.	PTFE-liner cpl.	Embout+gaine PTFE	Sirga de PTFE cplt.
481P101001	WIG-Kaltdrahtzuführung	TIG Cold Wire feed unit, small	Système TIG fil, petit	Unidad de hilo frío pequeña
481P102017	Spezial Isolator	Special Isolator	Isolant spécial	Aislante para equipo de hilo frío

Aufbau der WIG-Kaltdrahtzuführung am Brenner SR17/SR18/26  
 Details of TIG-Cold-Wire-Feeding for Torch SR17/SR18/26  
 Installation du TIG-fil froid sur la torche SR17/SR18/26  
 Detalles del TIG alimentación de hilo frío en la antorcha SR17/SR18/26

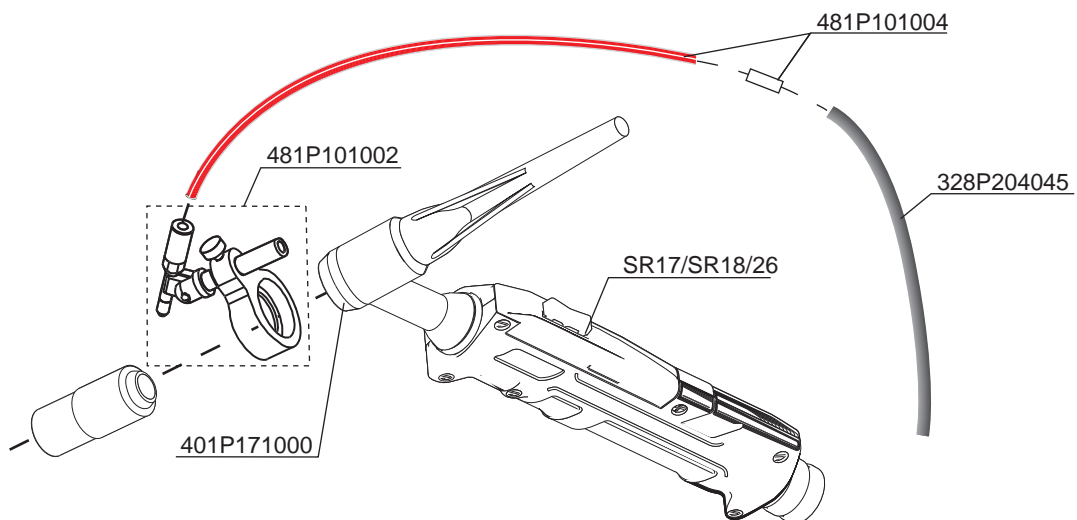

328P204045	PA-Drahtführung (4.50m) für Draht 1.0-1.2	PA-liner (4.50m) for wire 1.0-1.2	Gaine-PA (4.50m) fil 1.0-1.2	PA-Guia (4.50m) para hilo 1.0-1.2
481P101004	PTFE-Seele kpl.	PTFE-liner cpl.	Embout+gaine PTFE	Sirga de PTFE cplt.
481P101002	WIG-Kaltdrahtzuführung	TIG Cold Wire feed unit, large	Système TIG fil, grand	Unidad de hilo frío grande
401P171000	Isolator	Isolator for standard gas lens	Bague isolante diffuseur	Aislante para gas lens

**481P101001 und 481P101002**

WIG-Kaltdrahtzuführung für Brenner: (A) = SR 9 und SR 20; (B) = SR 17, SR 18 und SR 26

TIG-Cold-Wire-Feeding for Torches: (A) = SR 9 and SR 20; (B) = SR 17, SR 18 and SR 26

TIG fil froid pour torche: (A) = SR 9 and SR 20; (B) = SR 17, SR 18 et SR 26

TIG alimentación de hilo frío para antorchas: (A) = SR 9 and SR 20; (B) = SR 17, SR 18 y SR 26

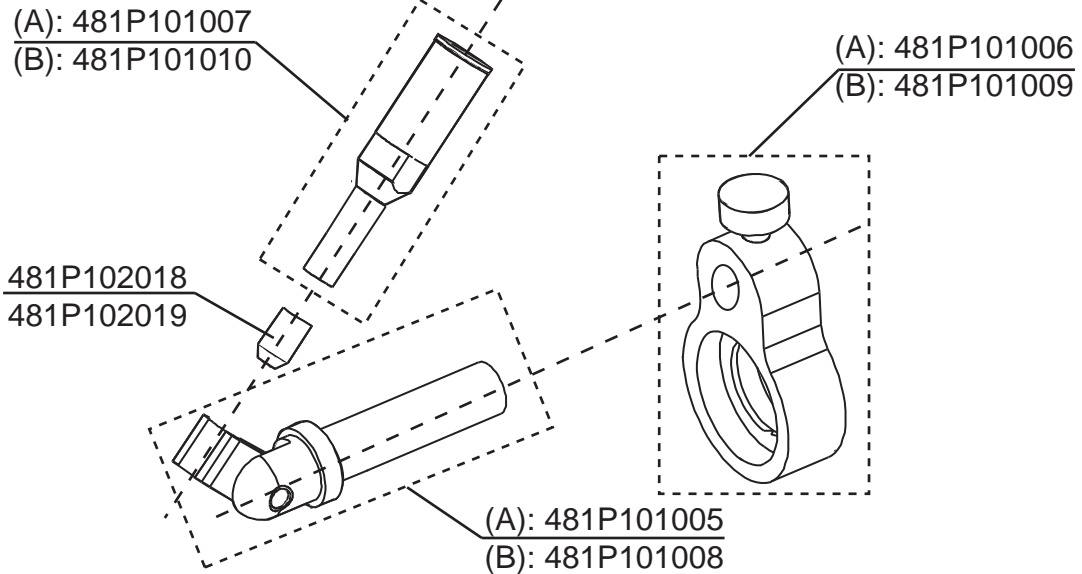
**Manual Torch**

481P101005	Drehaufnahme kpl.	Rotary support cpl.	Support tournant complet	Soporte para TIG hilo frío, pequeño
481P101008	Drehaufnahme kpl.	Rotary support cpl.	Support tournant complet	Soporte para TIG hilo frío, grande
481P101006	Brenneraufnahme	Neck support	Support pour torche	Soporte para TIG hilo frío, pequeño
481P101009	Brenneraufnahme	Neck support	Support pour torche	Soporte para TIG hilo frío, grande
481P101007	Einlaufdüse kpl.	Inlet guide, cpl.	Guide fil	tobera cplt. para hilo frío pequeño
481P101010	Einlaufdüse kpl.	Inlet guide, cpl.	Guide fil	tobera cplt. para hilo frío grande
481P102018	Düsenspitze 0.8-1.0	Wire outlet guide 0.8-1.0	Buse sortie fil 0.8-1.0	Tobera para guiar el hilo 0.8-1.0mm
481P102019	Düsenspitze 1.0-1.6	Wire outlet guide 1.0-1.6	Buse sortie fil 1.0-1.6	Tobera para guiar el hilo 1.0-1.6mm

**481P101003**

WIG-Kaltdrahtzuführung für 400S

TIG Cold Wire Feeder for 400S

TIG fil froid pour 400S

TIG alimentación de hilo frío para 400S

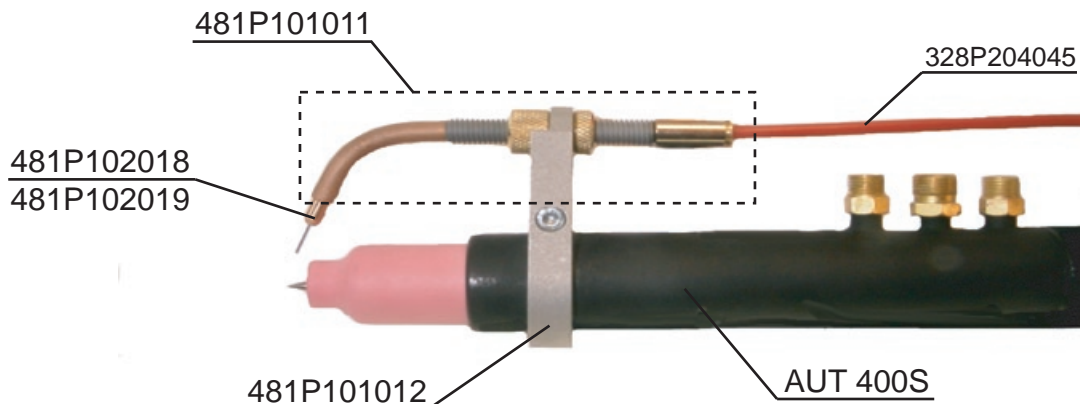
**Automatic Torch**

328P204045	PA-Drahtführung (4.50m) für Draht 1.0-1.2	PA-liner (4.50m) for wire 1.0-1.2	Gaine-PA (4.50m) fil 1.0-1.2	PA-Guia (4.50m) para hilo 1.0-1.2
481P101011	Drahtzuführung kpl.	Wire Feeder cpl.	Alimentation du fil froid cpl	Alimentación de hilo completo
481P101012	Halterung kpl.	Support cpl.	Support cpl	Soporte completo
481P102018	Düsenspitze 0.8-1.0	Wire outlet guide 0.8-1.0	Buse sortie fil 0.8-1.0	Tobera para guiar el hilo 0.8-1.0mm
481P102019	Düsenspitze 1.0-1.6	Wire outlet guide 1.0-1.6	Buse sortie fil 1.0-1.6	Tobera para guiar el hilo 1.0-1.6mm